



aerospace
climate control
electromechanical
filtration
fluid & gas handling
hydraulics
pneumatics
process control
sealing & shielding



K220LS

Mobile Directional Control Valve

Proportional, Load Sensing, Pre-compensated



ENGINEERING YOUR SUCCESS.

Catalogue layout

This catalogue has been designed to give a brief overview of K220LS valves, and to make it easy for you to study and choose from the different options available, so that we may customize your valve in accordance with your wishes. In addition to general information and basic technical data, the catalogue therefore contains descriptions of the options available for various so-called "function areas" of the valve.

Each function area is given as a subheading, followed by a brief description. When options are available for a function area, the subheading is followed by an "Item number" in brackets, e.g. Pressure relief valve [16]. This is followed by a series of coded options, e.g. **PA1, Y1**, together with a brief description of what each code represents. Alternatively, one or more pressure, flow or voltage options are given.

Please note that, unless stated otherwise, all sections and views of the valves have been drawn as seen from the inlet section.

How to order your valve

The K220LS directional control valve can be easily specified using Parker computer programme. This means the customer can optimise his valve specification to give the best performance for his application and specific hydraulic system.

Once the demands placed on each individual function have been specified the computer will select the valve design required to give optimum performance. The computer also produces complete documentation for your valve, in the form of a detailed specification and hydraulic circuit diagram.

The computer also generates a unique identification number for each valve type and customer. The number is then stamped into the I.D. plate of each valve. The specification of your valve is then recorded by Parker, so that exact identification of the product can be made at any time in the future to facilitate repeat ordering or servicing.

Early consultation with Parker saves time and money

Our experienced engineers have in-depth knowledge of the different types of hydraulic system and the ways in which they work. They are at your disposal to offer qualified advice on the best system for the desired combination of functions, control characteristics and economic demands. By consulting Parker early in the project planning stage, you are assured of a comprehensive hydraulic system that gives your machine the best possible operating and control characteristics.

Conversion factors

1 kg	= 2.2046 lb
1 N	= 0.22481 lbf
1 bar	= 14.504 psi
1 l	= 0.21997 UK gallon
1 l	= 0.26417 US gallon
1 cm ³	= 0.061024 in ³
1 m	= 3.2808 feet
1 mm	= 0.03937 in
9/5 °C + 32	= °F



WARNING – USER RESPONSIBILITY

FAILURE OR IMPROPER SELECTION OR IMPROPER USE OF THE PRODUCTS DESCRIBED HEREIN OR RELATED ITEMS CAN CAUSE DEATH, PERSONAL INJURY AND PROPERTY DAMAGE.

This document and other information from Parker-Hannifin Corporation, its subsidiaries and authorized distributors provide product or system options for further investigation by users having technical expertise.

The user, through its own analysis and testing, is solely responsible for making the final selection of the system and components and assuring that all performance, endurance, maintenance, safety and warning requirements of the application are met. The user must analyze all aspects of the application, follow applicable industry standards, and follow the information concerning the product in the current product catalog and in any other materials provided from Parker or its subsidiaries or authorized distributors.

To the extent that Parker or its subsidiaries or authorized distributors provide component or system options based upon data or specifications provided by the user, the user is responsible for determining that such data and specifications are suitable and sufficient for all applications and reasonably foreseeable uses of the components or systems.

Offer of Sale

Please contact your Parker representation for a detailed "Offer of Sale".

Contents	Page
General Information.....	4
Technical Data.....	5
Inlet Section.....	7
Spool Section	8
Connections [04] and [47].....	8
Mid-inlet section [90-99].....	8
Pressure compensator and/or load-hold check valve [66].....	9
Feed reducer valve [75].....	9
Dimensional Drawings.....	10

[00] refers to item numbers in the customer specification.

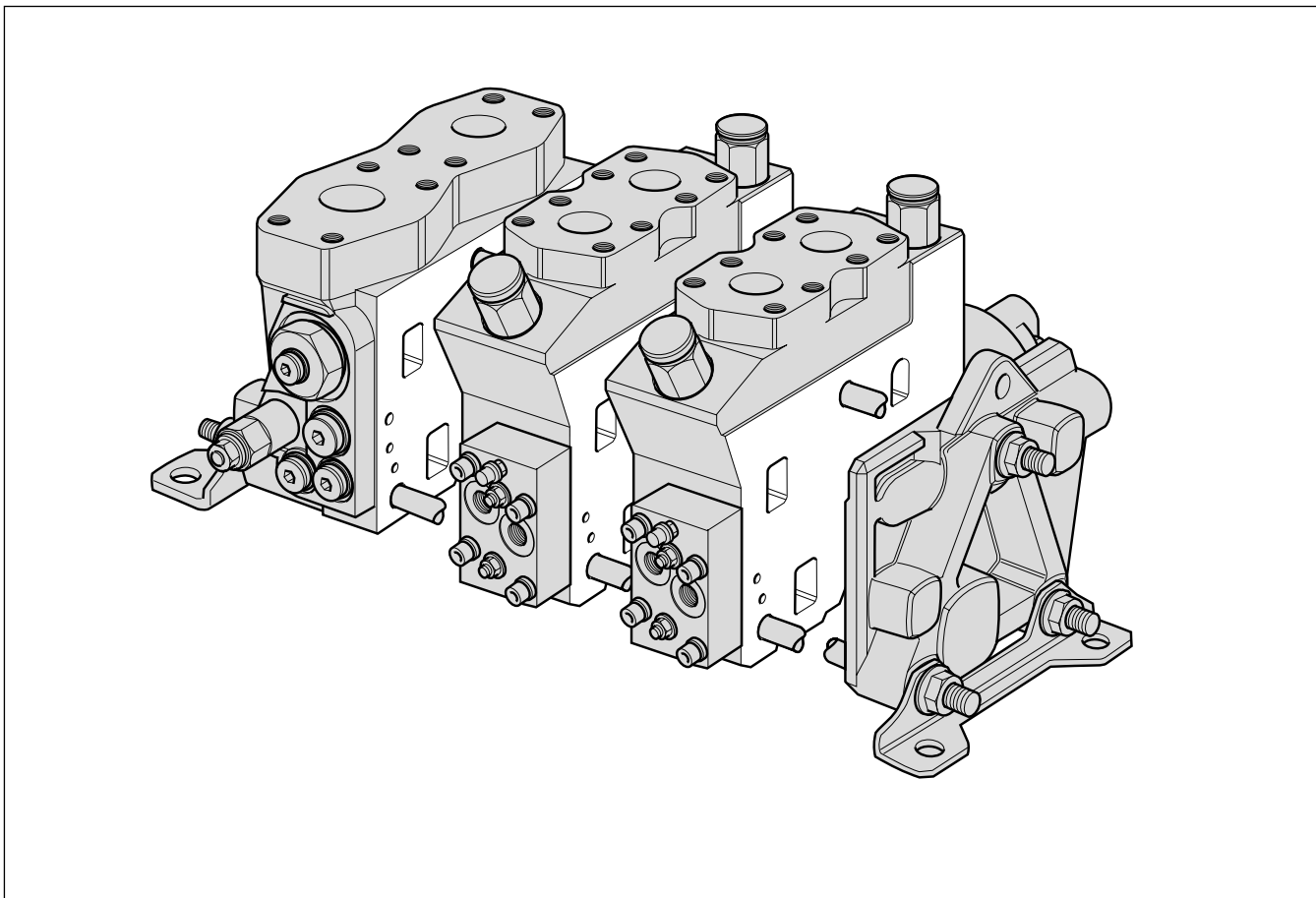

The K220LS is a development of our K170LS directional valve and this leaflet serves only as a complement to the K170LS product catalogue. The numeric codes [00] used in the illustrations and with the sub-headings for specifiable valve functions are therefore the same as those used in the K170LS catalogue and the product specification program.

Compact system construction

Many system functions can be integrated into the K220LS, reducing the number of components simplifying the installation. By means of an adapter plate, the K220LS can be combined with the smaller L90LS directional valve to serve functions requiring lower flow. This arrangement is very compact and economical.

Freedom in machine design

The K220LS is supplied with spool actuators for either hydraulic or electro-hydraulic proportional remote control. This gives great flexibility in terms of component location and the running of pipework, hoses and electric cables.

Economy

The K220LS can be rebuilt - to increase or reduce the number of spools - at any time to suit the needs of the customer. Moreover, the various valve functions can be adapted to suit the application in question, thus keeping energy consumption to a minimum.

Control characteristics

Thanks to unique function-adapted valve spools, the K220LS gives outstanding control characteristics in both the lifting and lowering movements.

Design

Sectional construction - The K220LS is sectionally built and can be supplied in combinations of 1 to 7 spool sections. It is designed for a system pressure of 350 bar and can be used with pump flows of up to 280 l/min (2 x 280 l/min with mid-inlet section). The nominal maximum flow per spool section is 200 l/min with compensator.

Pressure compensation - An individual pressure compensator in each spool section gives excellent control characteristics.

Feed reducer(s) - Common or individual feed reducers can be adjusted between 30 and 330 bar, limiting the pressure in the respective service ports. Pressure reduction is achieved through the pressure compensator, which shuts off the oil flow.

Force feedback - Force-regulating control characteristics give not only efficient acceleration of swing functions but also more gentle transition in speed changes.

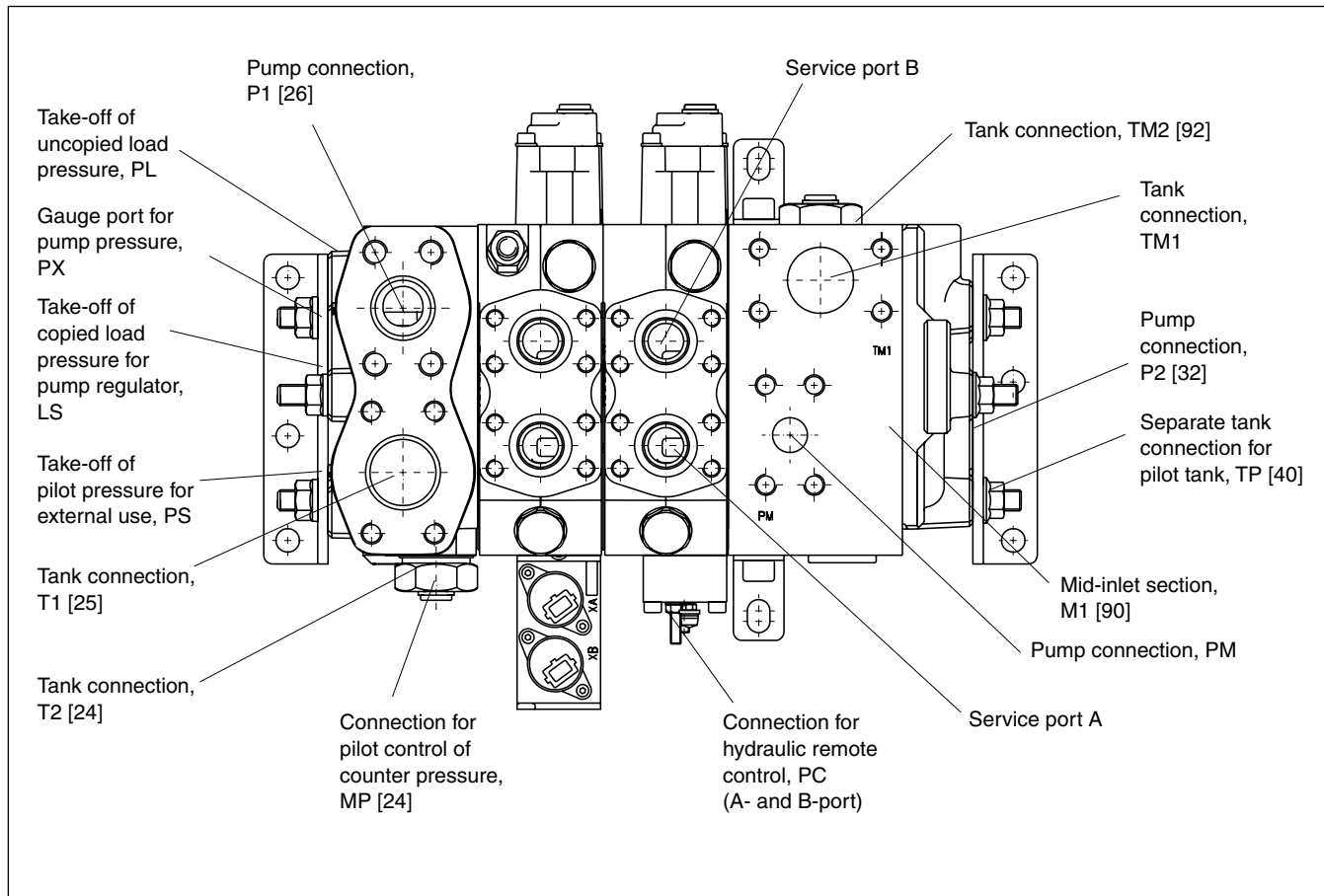

Pressure

Pump inlet	max. 350 bar (5075 psi) ¹⁾
Service ports	max. 350 bar (5075 psi) ¹⁾
Pump regulator Compensator K3	Δp min. 18 bar (260 psi) ²⁾
Return line pressure (static)	Δp min. 30 bar (435 psi) ²⁾ max. 20 bar (290 psi)

¹⁾ Stated pressures are maximal absolute shock pressures at 10 bar (145 psi) tank pressure
²⁾ Pressure drop from pump to valve max. 3 bar (45 psi)

Temperature

Oil temperature, working range	+20 °C to +90 °C* (68 to 194 °F)
--------------------------------	-------------------------------------

Filtration

Filtration must be arranged so that Target Contamination Class 20/18/14 according to ISO 4406 is not exceeded. For the pilot circuit, Target Contamination Class 18/16/13 according to ISO 4406 must not be exceeded.

Hydraulic fluids

Best performance is obtained using mineral-base oil of high quality and cleanness in the hydraulic system. Hydraulic fluids of type HLP (DIN 51524), oil for automatic gear-boxes Type A and engine oil type API CD can be used.

Viscosity, working range 15-380 mm²/s**

Technical information in this catalogue is applicable at an oil viscosity of 30 mm²/s and temperature of 50 °C (122 °F) using nitrile rubber seals.

* Product operating limits are broadly within the above range, but satisfactory operation within the specification may not be accomplished. Leakage and response will be affected when used at temperature extremes and it is up to the user to determine acceptability at these levels.

** Performance efficiency will be reduced if outside the ideal values. These extreme conditions must be evaluated by the user to establish suitability of the products performance.

Weight

The weights given below are approximate, since they vary somewhat depending on valve configuration.

Inlet section	11.4 kg	25.1 lb
Spool section with PC spool actuator	13.1 kg	28.9 lb
Spool section with EC spool actuator	14.5 kg	32.0 lb
End section	4.1 kg	9.0 lb
Combi-inlet	11.5 kg	25.4 lb

Connections

P1, PM, T1, TM and the service ports A and B are fitted with so-called flange plane connections according to ISO 6162-1/2. Fixing screws for the flanges are available in two versions, UNC and metric.

Other connections are available in two versions:

G-version (BSP pipe thread) for flat seal (type Tredo) as per ISO 228/1 and UNF-version for O-ring seal as per ISO 11926-1.

Conne- ction	In section	G-ver- sion.	UNF-version
P1	inlet section	Flange SAE 1 High pres- sure ISO 6162-2 ¹⁾	
T1	inlet section	Flange SAE 1 1/4 Std pressure ISO 6162-1 ³⁾	
T2	inlet section	G 1	1 5/16-12 UN-2B
P1	combo-inlet CA/CL	Flange SAE 1 High pres- sure ISO 6162-2 ¹⁾	
T1	combo-inlet CA/CL	Flange SAE 1 1/4 Std pressure ISO 6162-1 ³⁾	
T2	combo-inlet CA/CL	G 1	1 5/16-12 UN-2B
LS, PL, PX, PS	inlet, combo-inlet CA/CL	G 1/4	9/16-18 UNF-2B
MP	inlet section	G 1/4	9/16-18 UNF-2B
PM	mid-inlet section	Flange SAE 1 High pres- sure ISO 6162-2 ¹⁾	
TM	mid-inlet section	Flange SAE 1 1/4 Std pressure ISO 6162-1 ¹⁾	
TM2	mid-inlet section	G 1	1 5/16-12 UN-2B
P2	end section	G 1	1 5/16-12 UN-2B
T3	end section	G 1/4	9/16-18 UNF-2B
TP	end section	G 1/4	9/16-18 UNF-2B
TP	combo-inlet CA/CL	G 3/8	3/4-16 UNF-2B
LSP	end section	G 3/8	9/16-18 JIC (37°) (male)
YS	combo-inlet CA/CL	G1/4	9/16-18 JIC (37°) (male)
A, B	spool section	Flange SAE 1 Std pres- sure ISO 6162-1 ²⁾	
A, B	spool section	Flange SAE 3/4 High pres- sure ISO 6162-2 ²⁾	
PC	spool section	G 1/4	9/16-18 UNF-2B

¹⁾ Screw M12 or 7/16-14 UNC, depth of thread ≥ 25 mm

²⁾ Screw M10 or 3/8 - 16 UNC, depth of thread ≥ 20 mm

³⁾ Screw M10 or 7/16-14 UNC, depth of thread ≥ 20 mm

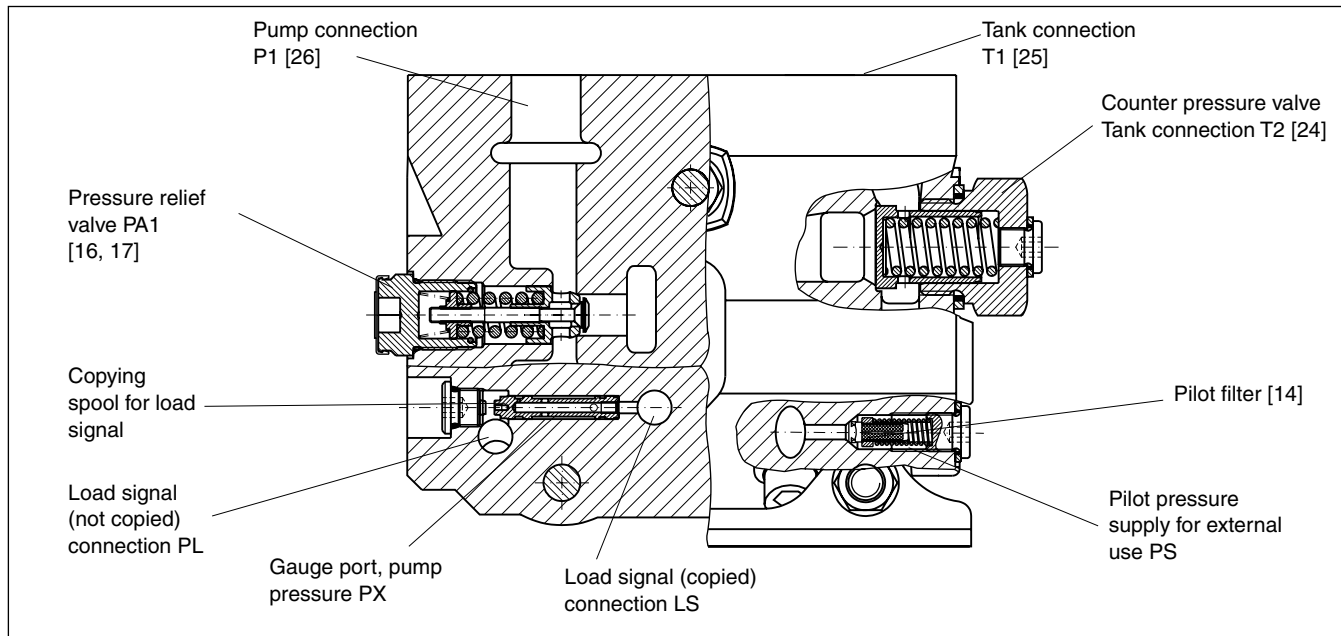

Inlet section [12-29]

The inlet section is equipped with a pump connection (P1) and two tank connections (T1, T2). It is also equipped with connections for a copied load signal to the pump (LS), an uncopied load signal to a subsequent valve (PL), a gauge point for measuring the pump pressure (PX), a take-off of reduced pump-pressure for external pilot-oil supply (PS) and a connection for transmitting the maximum load signal on to a subsequent valve (PL2).

The inlet section also contains a copying spool for copying the load-signal pressure, a reducer valve with a built-in pressure relief for reducing the pump pressure to pilot pressure, a strainer to filter the pilot oil and a pressure relief valve that limits the maximum pressure of the valve, a counter pressure valve in T2. The strainer for the pilot oil can be replaced with an external filter.

AS Inlet section with flow distribution function for systems with variable pump. The section distributes the pump flow between activated spool sections fitted with compensator type KAS [66], at maximum flow take-off from the pump. With other inlet types, the consumer working the hardest receives no flow, which instead goes to the consumer with the lowest load. The section is equipped with a load pressure limiting valve, PLM [16], and a differential pressure limiting valve (pump pressure-load pressure), PLS [18]. Valves with AS inlet are located closest to the pump in a multi-valve system with the load signal connected to the pump regulator.

AS2 Inlet section for following valve in a flow distribution system. The load signal from this valve is connected to the preceding valve. Otherwise, the functionality is as for inlet section AS except that the section only contains a load pressure limiting valve, PLM [16].

IP Inlet plate without functions. Contains only connections for pump, tank and load signal.

LS2 Inlet section for systems with variable pump. Equipped with a non-adjustable, direct-acting pressure relief valve, PA1 [16], which protects the pump and inlet side of the valve. The LS2 variant is equipped with a copy function for the load signal.

CA/CL Combo inlet used as mid-inlet when L90 and K220 are assembled together. This works as an adapter plate between valves and replaces inlet sections from both valves. The combination inlet is available with the same functionality as the LS2, AS and AS2 inlets. It can also include pilot pressure supply and the counter pressure function.

For more information see the catalogue for L90LS.

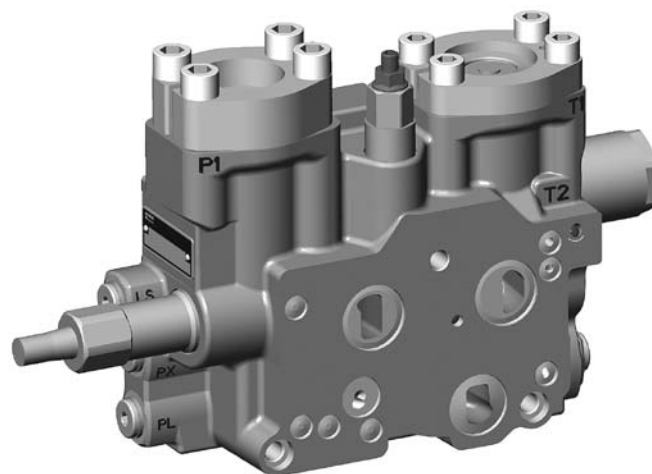

Combo-inlet CA

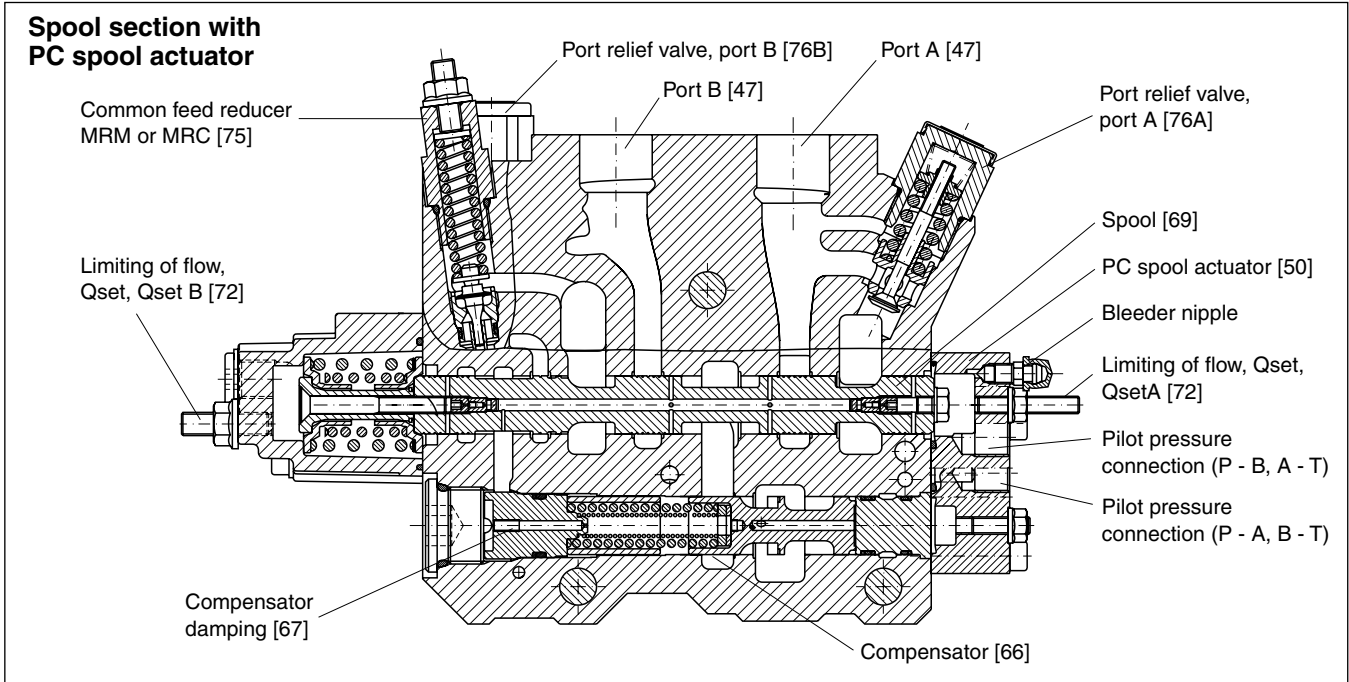

Spool section [45-89]

The K220LS is a stackable directional valve and can be supplied in combinations of 1 to 7 spool sections. Each section can be equipped individually to incorporate a large number of different

functions. By means of function-adapted spools, spool actuators, pressure relief valves, pressure compensators, etc. the valve can be optimized to suit different applications.

Connections [04] and [47]

The section service-port connections are the flange type according to ISO 6162-1/2. The fixing-screw threads are available in two versions, UNC and M. Other connections on the section are of G type according to ISO 228/1 (for flat seal) or UN type according to ISO 11926-1 (for O-ring seal). Please see page 6 for dimensions.

- MG** Flanged connection with M threaded fixing screws. Other connections of G type.
- MU** Flanged connection with M threaded fixing screws. Other connections of UN type.
- UU** Flanged connection with UNC threaded fixing screws. Other connections of UN type.
- FCS** Spool section with service ports A and B according to ISO 6162-1/2 Standard Pressure.
- FCH** Spool section with service ports A and B according to ISO 6162-1/2 High Pressure.

Mid-inlet section [90-99]

In certain applications, e.g. the feeding of crawler-track motors on an excavator, there is a demand for high flow from two sections at the same time. This can be achieved by means of the mid-inlet section MI [90], which can be mounted anywhere in the valve. Ideally, however, the high flows should be obtained from the first and last spool sections, and the mid-inlet section should be mounted between the last spool section and the end section. Valves with mid-inlet sections can be fed with a pump flow of 2 x 280 l/min. The mid-inlet section also contains two tank connec-

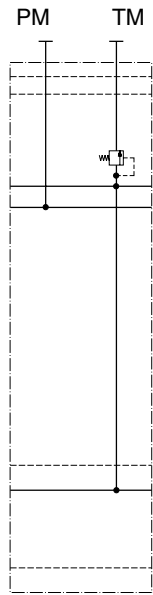

Mid-inlet section with counter pressure valve.

tions or, alternatively, one tank connection and a counter pressure valve (the same counter pressure valve that can be used in T2 [24].) There are two mounting plates on the mid-inlet section, one on each side. These should be used if the valve is to be mounted in any way other than with the service ports facing upward. See dimensional drawing on page 10.

**Pressure compensator and/or
 load-hold check valve [66]**

- K1** Fixed pressure compensator with load-hold check valve. The spool gives nominal flow.
- K2** Fixed pressure compensator with load-hold check valve. The spool gives 20% more than nominal flow.
- K3** Fixed pressure compensator with load-hold check valve. The spool gives 55% more than nominal flow. N.B. Pump must deliver a pressure of at least $\Delta p=30$ bar. (30 bar above load signal reported to pump regulator.)
- KN1** Fixed pressure compensator with extra fast load-hold check valve. The spool gives 15% more than nominal flow.
- KAS** Compensator for systems with flow distribution. In sections with KAS compensators, the flow take-off is reduced by the same percentage at maximum flow-take-off from the pump. With a pressure difference of 20 bar between PX and LS, the flow to the motor ports is about the same as with a compensator of type K3. If the same valve contains sections with compensators of type K1, K2, K3 or KN1, these will be given priority over sections with KAS compensators in terms of flow take-off. This makes it easy to establish priority for a specific function.
- KAP** Compensator for systems with flow distribution. In principle, the KAP compensator works in the same way as the KAS. The difference is that there is an extra spring causing the pump to motor port connection to be closed sooner than the KAS compensator, and sections with KAS compensators are given priority over sections with KAP compensators.
- N1** Load-hold check valve.
- X1** Prepared for compensator and load-hold check valve.

Feed reducer valve [75]

Any section in the K220LS can be equipped with individual feed reduction on service ports A and B.

Feed reduction is used for functions in a system which require a lower maximum pressure than the normal working pressure of the system. The reducer valve is adjustable and reduces the feed pressure in the section to a pre-set level.

By using a feed reducer valve, the feed pressure can be limited without consuming any more than a pilot flow (<2 l/min).

When using the feed reduction function, the section must be equipped with a pressure compensator as the feed reducer is a two-stage valve. Pressure shocks that arise after the feed reducer valve must be limited with the aid of a port relief valve. The pressure setting in the port relief valve [76 A,B] should be as close as possible to that in the feed reducer valve, but at least 10 bar higher.

- MR** Feed reducer for individual setting of maximum pressures in service ports A and B. Pressure settings from 30 to 330 bar.
- MRC** Feed reducer for common setting of maximum pressure in service ports A and B. Pressure settings from 175 to 330 bar.
- MRM** Feed reducer for common setting of maximum pressure in service ports A and B, as well as the service ports in all subsequent sections (seen from the inlet section). Sections located downstream of a section equipped with MRM can be equipped with individual feed reducer valves provided that they are set at lower values. Pressure settings from 175 to 330 bar.

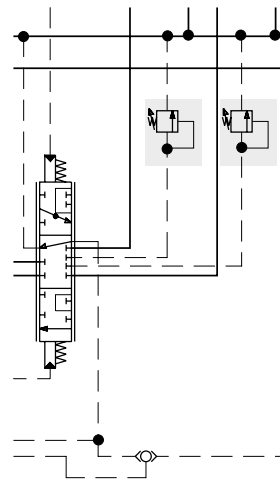

Section equipped with feed reducer valve type MR.

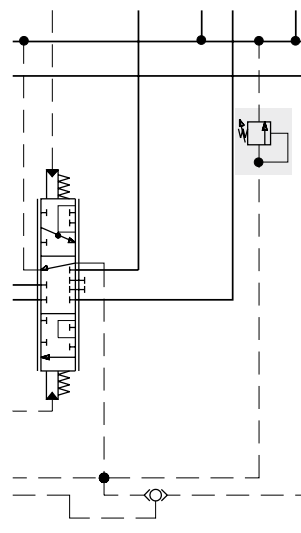

Section equipped with feed reducer valve type MRC.

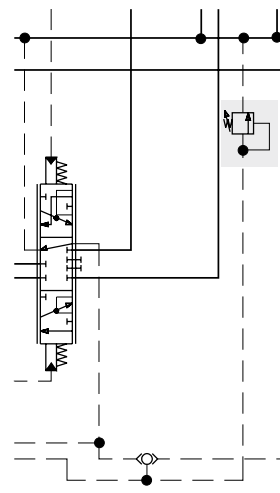

Section equipped with feed reducer valve type MRM.

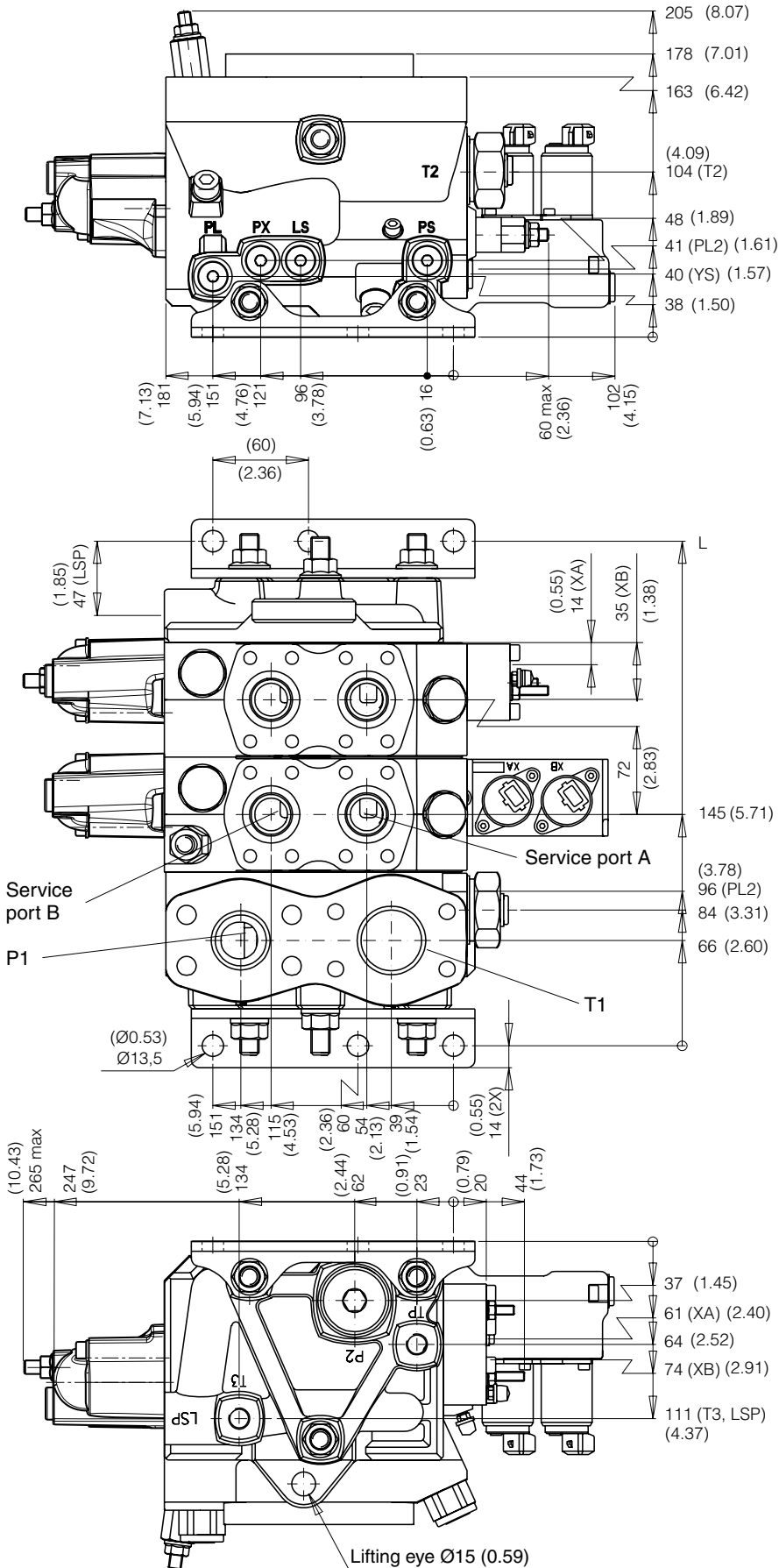

(inch)

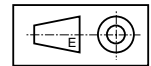

No. of sections	L mm	L inch
1	244	9.61
2	316	12.44
3	388	15.28
4	460	18.11
5	532	20.94
6	604	23.78
7	676	26.61

Mid-inlet section

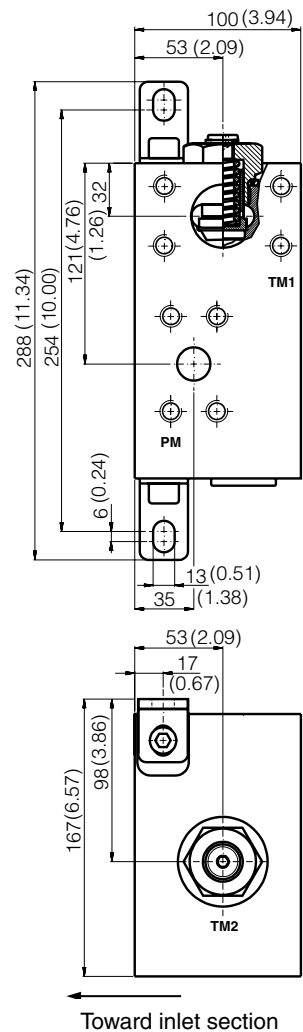

Parker Worldwide

Europe, Middle East, Africa

AE – United Arab Emirates,
Dubai

Tel: +971 4 8127100
parker.me@parker.com

AT – Austria, Wiener Neustadt

Tel: +43 (0)2622 23501-0
parker.austria@parker.com

AT – Eastern Europe, Wiener
Neustadt

Tel: +43 (0)2622 23501 900
parker.easteurope@parker.com

AZ – Azerbaijan, Baku

Tel: +994 50 2233 458
parker.azerbaijan@parker.com

BE/LU – Belgium, Nivelles

Tel: +32 (0)67 280 900
parker.belgium@parker.com

BY – Belarus, Minsk

Tel: +375 17 209 9399
parker.belarus@parker.com

CH – Switzerland, Etoy

Tel: +41 (0)21 821 87 00
parker.switzerland@parker.com

CZ – Czech Republic, Klecany

Tel: +420 284 083 111
parker.czechrepublic@parker.com

DE – Germany, Kaarst

Tel: +49 (0)2131 4016 0
parker.germany@parker.com

DK – Denmark, Ballerup

Tel: +45 43 56 04 00
parker.denmark@parker.com

ES – Spain, Madrid

Tel: +34 902 330 001
parker.spain@parker.com

FI – Finland, Vantaa

Tel: +358 (0)20 753 2500
parker.finland@parker.com

FR – France, Contamine s/Arve

Tel: +33 (0)4 50 25 80 25
parker.france@parker.com

GR – Greece, Athens

Tel: +30 210 933 6450
parker.greece@parker.com

HU – Hungary, Budapest

Tel: +36 1 220 4155
parker.hungary@parker.com

IE – Ireland, Dublin

Tel: +353 (0)1 466 6370
parker.ireland@parker.com

IT – Italy, Corsico (MI)

Tel: +39 02 45 19 21
parker.italy@parker.com

KZ – Kazakhstan, Almaty

Tel: +7 7272 505 800
parker.easteurope@parker.com

NL – The Netherlands, Oldenzaal

Tel: +31 (0)541 585 000
parker.nl@parker.com

NO – Norway, Asker

Tel: +47 66 75 34 00
parker.norway@parker.com

PL – Poland, Warsaw

Tel: +48 (0)22 573 24 00
parker.poland@parker.com

PT – Portugal, Leca da Palmeira

Tel: +351 22 999 7360
parker.portugal@parker.com

RO – Romania, Bucharest

Tel: +40 21 252 1382
parker.romania@parker.com

RU – Russia, Moscow

Tel: +7 495 645-2156
parker.russia@parker.com

SE – Sweden, Spånga

Tel: +46 (0)8 59 79 50 00
parker.sweden@parker.com

SK – Slovakia, Banská Bystrica

Tel: +421 484 162 252
parker.slovakia@parker.com

SL – Slovenia, Novo Mesto

Tel: +386 7 337 6650
parker.slovenia@parker.com

TR – Turkey, Istanbul

Tel: +90 216 4997081
parker.turkey@parker.com

UA – Ukraine, Kiev

Tel +380 44 494 2731
parker.ukraine@parker.com

UK – United Kingdom, Warwick

Tel: +44 (0)1926 317 878
parker.uk@parker.com

ZA – South Africa, Kempton Park

Tel: +27 (0)11 961 0700
parker.southafrica@parker.com

North America

CA – Canada, Milton, Ontario

Tel: +1 905 693 3000

US – USA, Cleveland

(industrial)
Tel: +1 216 896 3000

US – USA, Elk Grove Village

(mobile)
Tel: +1 847 258 6200

Asia Pacific

AU – Australia, Castle Hill

Tel: +61 (0)2-9634 7777

CN – China, Shanghai

Tel: +86 21 2899 5000

HK – Hong Kong

Tel: +852 2428 8008

IN – India, Mumbai

Tel: +91 22 6513 7081-85

JP – Japan, Fujisawa

Tel: +81 (0)4 6635 3050

KR – South Korea, Seoul

Tel: +82 2 559 0400

MY – Malaysia, Shah Alam

Tel: +60 3 7849 0800

NZ – New Zealand, Mt Wellington

Tel: +64 9 574 1744

SG – Singapore

Tel: +65 6887 6300

TH – Thailand, Bangkok

Tel: +662 717 8140

TW – Taiwan, Taipei

Tel: +886 2 2298 8987

South America

AR – Argentina, Buenos Aires

Tel: +54 3327 44 4129

BR – Brazil, Sao Jose dos

Campos
Tel: +55 12 4009 3500

CL – Chile, Santiago

Tel: +56 2 623 1216

MX – Mexico, Apodaca

Tel: +52 81 8156 6000

VE – Venezuela, Caracas

Tel: +58 212 238 5422

EMEA Product Information Centre

Free phone: 00 800 27 27 5374

(from AT, BE, CH, CZ, DE, DK, EE, ES, FI, FR, IE, IL,
IS, IT, LU, MT, NL, NO, PL, PT, RU, SE, SK, UK, ZA)

US Product Information Centre

Toll-free number: 1-800-27 27 537

www.parker.com

